

# Differential progression of proprioceptive and visual information processing deficits in Parkinson's disease

N. L. W. Keijsers,<sup>1</sup> M. A. Admiraal,<sup>1</sup> A. R. Cools,<sup>2</sup> B. R. Bloem<sup>3</sup> and C. C. A. M. Gielen<sup>1</sup>

<sup>1</sup>Department of Biophysics, Institute for Neuroscience, BEG 231, Radboud University Nijmegen, Geert Grooteplein 21, 6525 EZ Nijmegen, Postbus 9101, The Netherlands

<sup>2</sup>Department of Psychoneuropharmacology, Radboud University Nijmegen, The Netherlands

<sup>3</sup>Department of Neurology, Institute for neuroscience, University Medical Center St Radboud, Nijmegen, The Netherlands

**Keywords:** disease severity, Parkinson's disease, pointing movements, sensorimotor processing, visual feedback

## Abstract

Indirect evidence suggests that patients with Parkinson's disease (PD) have deficits not only in motor performance, but also in the processing of sensory information. We investigated the role of sensory information processing in PD patients with a broad range of disease severities and in a group of age-matched controls. Subjects were tested in two conditions: pointing to a remembered visual target in complete darkness (DARK) and in the presence of an illuminated frame with a light attached to the index finger (FRAME). Differences in pointing errors in these two conditions reflect the effect of visual feedback on pointing. PD patients showed significantly larger constant and variable errors than controls in the DARK and FRAME condition. The difference of the variable error in the FRAME and DARK condition decreased as a function of the severity of PD. This indicates that any deficits in the processing of proprioceptive information occur already at very mild symptoms of PD, and that deficits in the use of visual feedback develop progressively in later stages of the disease. These results provide a tool for early diagnosis of PD and shed new light on the functional role of the brain structures that are affected in PD.

## Introduction

The accuracy of pointing movements depends to a large extent on the availability of visual and proprioceptive information. When pointing to remembered visual targets in complete darkness, proprioceptive information provides the most reliable source of information about finger position (van Beers *et al.*, 1999, 2002). With visual feedback of finger position, the accuracy of pointing increases, especially in the direction of azimuth and elevation, and to a lesser extent also in depth (depth refers to radial direction relative to the observer) (van Beers *et al.*, 2002; Admiraal *et al.*, 2003). These properties of proprioceptive and visual information processing in man explain why errors for pointing to remembered visual targets have three-dimensional ellipsoidal distributions (Soechting & Flanders, 1989a, 1989b; Gordon *et al.*, 1994; McIntyre *et al.*, 1997, 1998; Messier & Kalaska, 1997, 1999; Desmurget *et al.*, 1998) with the long axis directed towards the subject and why pointing becomes more accurate with the availability of visual feedback (Admiraal *et al.*, 2003).

Pointing to remembered visual targets has previously been used to investigate deficits in sensory information processing in patients with Parkinson's Disease (PD) (Adamovich *et al.*, 2001; Ketcham *et al.*, 2003). PD patients have well-known movement abnormalities including bradykinesia (slowness of movement), hypokinesia (lack of movement), akinesia (inability to initiate a movement), tremor and rigidity. In addition to these well-known movement abnormalities, recent studies suggest that PD patients also have deficits in the processing of sensory inputs, particularly in the processing of

proprioceptive inputs (Schneider *et al.*, 1987; Klockgether *et al.*, 1995; Jobst *et al.*, 1997; Rickards & Cody, 1997; Zia *et al.*, 2000). For example, PD patients were less sensitive in identifying the occurrence and direction of externally imposed movements (Schneider *et al.*, 1987). Furthermore, PD patients produce larger errors than controls in static joint position sense of the elbow (Zia *et al.*, 2000) and PD patients are less accurate in detecting limb displacements (Maschke *et al.*, 2003). PD patients also make larger errors than normal subjects in reproducing a passive finger movement (Zia *et al.*, 2000) and make larger errors in matching the position of a passively moved finger to the position of a visual target (Klockgether *et al.*, 1995). Because muscle spindle sensitivity is normal in PD (Delwaide & Gonce, 1993), the impaired joint position sense in PD seems primarily of central neural origin. This hypothesis is supported by the finding of reduced sensory-evoked brain activations in cortical (parietal and frontal) and subcortical (basal ganglia) areas in PD patients using positron emission tomography (Boecker *et al.*, 1999). Furthermore, a reduced level of intracortical inhibition was found in PD patients, which also suggested an abnormal influence of afferent input on corticomotor excitability (Lewis & Byblow, 2002). In addition to these findings in PD patients, Fillion *et al.* (1988) reported an increase in the number, magnitude, and loss of specificity of responses in the basal ganglia of MPTP-treated monkeys to passive limb movement. The latter study suggests that deficits in motor performance in PD are, at least partly, due to deficits in the processing of sensory (mainly proprioceptive) information in the basal ganglia.

Animal studies have shown that the ability to use sensory information depends on the degree of striatal dopamine loss (Cools *et al.*, 1993; Martens *et al.*, 1996; Henderson *et al.*, 2003). A minor dopamine deficit in the caudate nucleus only affects its first output

Correspondence: Dr N. L. W. Keijsers, as above.

E-mail: noelk@mbfys.kun.nl

Received 27 July 2004, revised 8 October 2004, accepted 26 October 2004

station, the substantia nigra pars reticulata. Animals with such a minor dopamine deficit showed a reduction in the ability to use static proprioceptive stimuli in motor control (Cools *et al.*, 1983; Jaspers *et al.*, 1984, 1989). Such animals could only switch between motor programs when external visual cues were available to direct their movement. Therefore, proprioceptive information processing was affected following minor dopamine deficits, but this could be overcome with the use of visual information. More severe dopamine deficits in the substantia nigra produce a GABA hyperactivity in the deeper layers of the colliculus superior (Scheel-Kruger, 1985). Animals with a mild GABA hyperactivity in the colliculus superior showed a reduced ability to use visual information in switching between motor patterns (Gelissen & Cools, 1986, 1987a, 1987b, 1988). Extrapolating these results to humans suggests that in an early stage of PD (a mild dopamine deficit), patients will produce larger errors in pointing than age-matched controls in a condition without visual information, but may perform equally well with the availability of visual feedback. However, with ongoing progression of PD, we hypothesize that patients will produce increasingly larger errors, even in conditions with visual information.

Previous studies on pointing to remembered visual targets in PD have reported that PD patients point less accurately than normal subjects in complete darkness while they are almost as accurate with visual guidance (Flash *et al.*, 1992; Klockgether & Dichgans, 1994; Adamovich *et al.*, 2001; Ketcham *et al.*, 2003). The pointing movements in these studies were only studied in two dimensions (Klockgether & Dichgans, 1994; Flash *et al.*, 1992; Ketcham *et al.*, 2003) or in three-dimensional, but then with a limited number of movements to a single target (Adamovich *et al.*, 2001). Due to the limited number of movements, an accurate determination of the constant and variable error in depth, azimuth and elevation could not be carried out. Moreover, these studies did not test the effect of severity of the disease on the accuracy of pointing.

Another interesting problem in pointing movements is related to the frame of reference, which is used for the preparation, planning and execution of the movement. Many studies have used pointing to remembered visual targets as a way to investigate which frames of reference are involved in pointing movements in various conditions. Most studies have reported a viewer-centred frame of reference with the origin located near the head or between the head and the shoulder (see, e.g. Soechting & Flanders, 1989a,b; Soechting *et al.*, 1990; Gordon *et al.*, 1994; McIntyre *et al.*, 1997; Messier & Kalaska, 1997, 1999; Desmurget *et al.*, 1998; Carrozzo *et al.*, 1999; Admiraal *et al.*, 2003). As explained by Admiraal *et al.* (2003) subjects store a remembered target in a viewer centred frame of reference in a dark environment, whereas an allocentric frame of reference may help to improve accuracy when pointing to remembered targets in an illuminated environment. As PD patients may benefit from visual cues during walking or to induce a step (Azulay *et al.*, 1999; Lewis *et al.*, 2000), PD patients might also use different frames of reference for the preparation, planning, and execution of their movements in different experimental conditions.

In this study we have investigated the constant and variable errors of pointing movements to remembered visual targets in PD patients with various degrees of severity of the disease, and in a group of age-matched controls. All subjects were tested in two conditions: pointing to a remembered visual target in complete darkness (DARK) and in the presence of an illuminated cubic frame with a light attached to the tip of the index finger (FRAME). The idea behind these experiments was: (i) that any differences in pointing errors in the two conditions reflect the effect of visual feedback in pointing by the subject; (ii) that any differences in accuracy of pointing might reveal information about

frames of reference used by Parkinson patients and (iii) that any differences in accuracy of pointing in the two conditions in patients with various degrees of PD may reveal an insight into the progressive effect of the disease on proprioceptive and visual information processing.

## Materials and methods

### Patients

This study included 12 patients (ten male, two female, age  $60 \pm 11$  years) who fulfilled the UK Brain Bank criteria for idiopathic PD (Hughes *et al.*, 1992). All patients sustained a clear beneficial response to treatment with levodopa or a dopamine agonist. Controls included ten healthy elderly subjects that were matched for age and sex (eight male, two female, age  $61 \pm 10$ ). Five patients had no anti-parkinsonian medication, whereas seven patients had anti-parkinsonian medication in various combinations. The clinical details of the PD patients are given in Table 1. All subjects in this study (both normal subjects and PD patients) had normal vision (or corrected to normal) and did not have oculomotor problems (except for minimal saccadic intrusions during smooth pursuit) or neurological disorders other than PD. We also excluded patients with dementia, a postural tremor of the arms within the first few seconds of assuming a sustained posture [score  $\geq 1$  on item 21 of the Unified Parkinson's Disease Rating Scale (UPDRS), Lang, 1995] or significant dyskinesias (score  $> 2$  on the Modified Dyskinesia Rating Scale, Goetz *et al.*, 1994). We did not exclude patients with a 'resetting' rest tremor of the arms that became apparent only after several seconds of assuming a sustained posture, i.e. well after completion of each individual pointing movement. Patients were examined in a defined 'off state' after overnight withdrawal of all anti-parkinson medication (Defer *et al.*, 1999). All patients had predictable end-of-dose wearing off effects and the interval between start of the experiments and intake of the last

TABLE 1. Characteristics of PD patients

Patient number	Sex	Age (years)	Disease duration (years)	H & Y stage	UPDRS score	Medication (per 24 h)
1	M	71	1	2	18	–
2	M	74	5	2	47	–
3	M	54	4.5	3	38	LC (3 × 125), DRA (4 × 0.25)
4	M	67	2	2.5	54	–
5	M	52	4	2	35	–
6	M	56	12	2	33	DRA (3 × 1), S (2 × 5)
7	F	72	1.5	2	30	LC (3 × 62.5)
8	M	37	1.5	2	37	DRA (3 × 2)
9	M	58	4	2.5	32	–
10	M	72	7	2.5	43	LC (5 × 137.5), DRA (3 × 5), Am (2 × 100)
11	F	63	1.5	2	26	An (7 × 2)
12	M	52	16	3	68	LC (9 × 125), DRA (4 × 4), Am (2 × 100), C (4 × 200), S (2 × 5)
Mean		60	5.0	2.3	38	
SD		11	4.7	0.5	13	

H & Y, Hoehn and Yahr; medication: LC, levodopa/carbidopa; DRA, dopamine receptor agonist; Am, amantadine; C, anticholinergic; S, selegiline.

medication was at least 12 h. Although it may be necessary to withdraw anti-parkinson medication for several days to entirely eliminate treatment effects, this approach allows for assessment of parkinsonian manifestations in a fairly stable 'off' state (Defer *et al.*, 1999).

Immediately before the experiments, the patients were clinically examined by an experienced movement disorders specialist (BRB) using the modified Hoehn and Yahr stages and the Unified Parkinson's Disease Rating Scale (UPDRS, Lang, 1995; Table 1). The experiments were approved by the Medical Ethical Committee of the University Medical Center of Nijmegen. All subjects gave witnessed and signed informed consent according to the Declaration of Helsinki, but the participants were not informed about the specific purposes of the study.

### Experimental paradigm

The experimental paradigm is almost similar to that used in a previous study by Admiraal *et al.* (2003). In contrast to the study of Admiraal *et al.* (2003), eye-movements were not measured in the present study. Figure 1 shows a schematic overview of the experimental setup. Subjects were seated upright in a chair with their hands on their knees facing a flat backboard (100 cm wide  $\times$  80 cm high) placed at a distance of approximately 85 cm in front of the subjects shoulder. Subjects had to point to the position of one out of five targets, which were presented as illuminated light-emitting-diodes (LEDs) on a metal

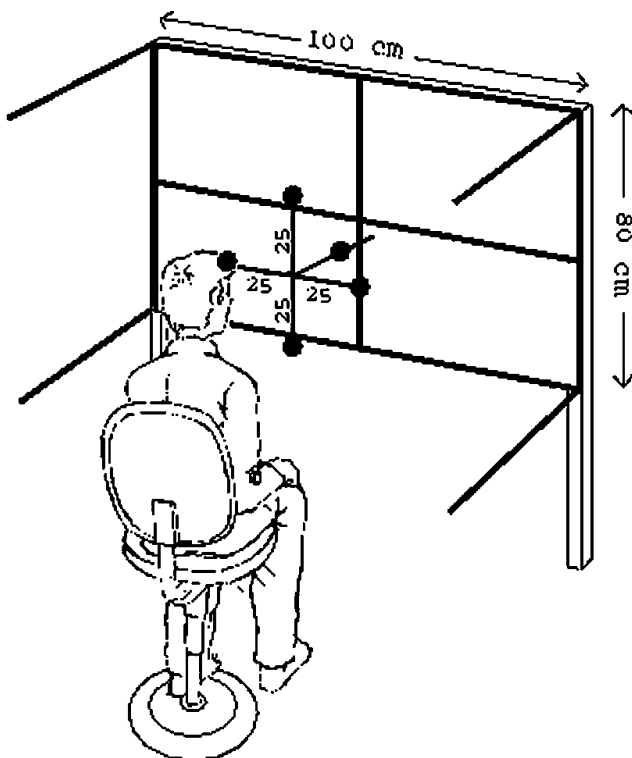

FIG. 1. Schematic overview of the experimental setup. Subjects were seated upright facing a flat backboard. During target presentation, the centre of the cross was at a distance of approximately 40 cm in front of the subject (45 cm in front of the backboard) and at a position halfway between the line between the subject's shoulder and the eyes. Four targets were on the vertices of the cross, which were 25 cm from the centre of the cross. A fifth target was placed on a stick, 25 cm from the centre of the cross. The illuminated optic fibers in the FRAME condition are presented as bold lines.

cross. The cross with targets was positioned reproducibly at a position between the subject and the board with a moveable stick. For each trial one of the LEDs was switched on for one second. After offset of the target LED, the cross was removed by the experimenter such that the subject could point to the remembered target without touching the metal cross or stick. During target presentation, the centre of the cross was at a distance of approximately 40 cm in front of the subject's shoulder (45 cm in front of the backboard) and at a position halfway between the line between the subject's shoulder and the eyes. Four LEDs were positioned on the vertices of the cross, at a distance of 25 cm from the centre of the cross. A fifth LED was placed on the stick, 25 cm behind the centre of the cross and 20 cm in front of the backboard. All subjects could easily reach all targets without full extension of their arm.

Each target presentation consisted of illumination of one of the five red LEDs for a period of one second. Onset of the LED target marked the start of a trial. When the target LED was switched off, the target was quickly removed. Two seconds after target offset, an auditory signal (a tone of 1000 Hz) instructed the subject to start the pointing movement to the remembered target position. Subjects were explicitly instructed to wait for the auditory signal before starting the pointing movement, and to keep the index finger at the position of the remembered target for approximately half a second before they returned to the initial position. Subjects were instructed to position the tip of the index finger as to touch the remembered target location. They were allowed to make small corrections at the end of their movement.

All subjects made pointing movements to remembered visual targets with their right hand except for two PD patients who pointed with their left hand. These two patients showed almost no signs of PD on their right side but had clear signs on their left side. For these two patients, targets were presented at mirror-symmetric locations relative to the position between the left shoulder and the eyes instead of the regular position between the right shoulder and the eyes.

Subjects were tested in two conditions: pointing to the remembered target in complete darkness (DARK) and pointing in the presence of an illuminated cubic frame with a continuously lit red LED attached to the tip of the index finger (FRAME). In this FRAME condition, a well-defined visual environment was shown to the subject by means of illuminated optic fibers (diameter 2 mm) along the edges of the backboard (100 cm wide  $\times$  80 cm high), with an illuminated cross centred in the middle (100 cm wide  $\times$  80 cm high) and with four 60 cm long illuminated optic fibers orthogonal to the backboard (see Fig. 1). The frame was visible at all times in the FRAME condition and the targets were presented within the illuminated cubic frame.

The targets were presented in randomized order in blocks of 20 trials. Subjects started with a block of 20 test trials in the DARK condition and a block of 20 test trials in the FRAME condition in order to become familiar with the experiment. Data of these test trials were not included in further data analyses. Thereafter, subjects were tested in ten blocks of 20 trials, each randomized over the two conditions. This means that each target was presented 20 times to the subject in both the FRAME and DARK condition. A block of 20 trials lasted approximately 4 min, and after each block, the room lights were switched on for at least 30 s to avoid dark adaptation during the test.

### Experimental setup

Position of the subject's head, shoulder, arm, and index finger as well as the target position were measured with an OPOTRAK 3020 system (Northern Digital). This system measures the three-dimensional position of infrared-light-emitting-diodes (ireds) with a resolution

better than 0.2 mm within a range of approximately 1.5 m<sup>3</sup>. Ireds were placed on the subject's shoulder (acromion), elbow (epicondylus lateralis), and on the tip of the index finger. The position of the LED targets was measured by ireds directly placed on each of the LED's. Subjects were free to move their wrist and were free to rotate their head and were wearing a helmet with six ireds, so that the three-dimensional head orientation could be calculated. Movements were sampled at a rate of 100 Hz. Before each experiment, subjects had to look at the OPTOTRAK system with two ireds on each of the two eyes. In this way, the position of the eyes relative to the ireds on the head was known. This information was used to calculate the positions of the eyes and the cyclopean eye relative to the orientation of the head in three dimension. The position of the tip of the index finger was measured by means of an ired attached to a thimble on the index finger. This thimble also contained a visible red LED that provided the subject with feedback on finger position in the FRAME condition.

### Data analysis

Pointing position was defined as the position of the ired on the tip of the index finger at the end of the pointing movement towards the target. The end of the movement was defined as the time, when velocity of the index finger decreased below a threshold of 0.5 cm/s. The end position was defined as the averaged position (calculated over 100 ms) after the end of the movement. Both the constant errors and the variable errors were computed. The constant error is defined as the difference between the target position and the average of all pointing positions to that target. It reflects the general error in planning and execution of the pointing movement. The variable error reflects the distribution of the pointing positions towards a target relative to the average pointing position to that target and reflects the noise in planning and execution. The distribution of the pointing positions for each target is described by the three-dimensional covariance matrix  $S_i$ :

$$S_i = \frac{\sum_{j=1}^n \delta_j^i (\delta_j^i)^T}{n-1}$$

where  $n$  is the number of trials to target  $i$  and  $\delta_j^i = p_j^i - \bar{p}^i$  is the deviation of the finger position  $p_j^i$  for trial  $j$  to target  $i$  relative to the mean pointing position  $\bar{p}^i$  to target  $i$ . The three orthogonal eigenvectors of the covariance matrix  $S_i$  describe the orientations of the variable errors. The corresponding eigenvalues of the matrix give the size of the variable error along the eigenvectors. The total variable error for pointing to a target was computed as the volume of the ellipsoid with the eigenvectors as the three orthogonal axes, each with the length of the corresponding eigenvalue of the covariance matrix for that target. The eigenvalues of the covariance matrix  $S_i$  can be scaled to compute the limits that contain 95% of the data (For details, see McIntyre *et al.*, 1997). A  $\chi^2$  test was used to decide whether the three eigenvalues of the covariance matrix were statistically different (see Barlow, 1989). The eigenvector that corresponds to the largest eigenvalue will be referred to as the main axis of the distribution.

Spatial components of the constant errors were computed in a viewer-centred coordinate system with distance (overshoot/undershoot), azimuth (left/right) and elevation (upward/downward), relative to the cyclopean eye. Spatial components of the variable error were evaluated using the eigenvectors of the covariance matrix. The eigenvector mostly directed towards the eyes will be referred to as the direction of variable error in radial distance. For most targets, this eigenvector was the eigenvector with the largest eigenvalue in both the DARK and FRAME condition (see Fig. 2). The eigenvector that was

most dominant in the horizontal (vertical) plane will be referred to as the direction of the variable error in azimuth (elevation).

One control subject showed a constant error in the DARK condition that exceeded the average constant error of control subjects by 2.6 standard deviations. For this reason, this outlier was left out of the statistical analysis, resulting in a total of nine control subjects and 12 PD patients. Differences in constant errors and variable errors between controls and PD patients were tested using three-way ANOVA with one between groups factor (controls vs. PD patients) and two within factors [condition DARK and FRAME, and target location (five targets)]. Two-way ANOVA with one between groups factor (controls vs. PD patients) and one within factor (target location) was used to test for differences between controls and PD patients in the DARK and in the FRAME condition. A Tukey test was used for *posthoc* analyses. Correlation analyses were conducted to assess the relations between disease severity (UPDRS score) and error size.

## Results

### Group analysis

Figure 2 illustrates the main findings for pointing to remembered targets in the DARK (left panels) and the FRAME (right panels) condition for control subjects and for PD patients. It shows the pointing positions to remembered targets, the constant error (average pointing position relative to target position) and the variable error (distribution of the pointing positions relative to the average pointing position) for a control subject, for a mild PD patient (UPDRS score of 32) and for a severe PD patient (UPDRS score of 68). The variable and constant errors are considerably smaller in the FRAME condition than in the DARK condition for control subjects. These results are very similar to data previously reported for young normal subjects (range between 20 and 40 years of age; see, e.g. Soechting & Flanders, 1989a, 1989b; McIntyre *et al.*, 1997, 1998; Carozzo *et al.*, 1999; Admiraal *et al.*, 2003). For the severe PD patient, both the constant error and the variable error in the FRAME and DARK condition were considerably larger than for the control subject. The data for the severe PD patient, shown in Fig. 2, reveal a clear overshoot of target position. The variable error for the severe PD patient was particularly enlarged in azimuth and elevation direction. The mild PD patient showed errors that were very similar to that of the control subject in the FRAME condition, but showed larger errors than the control subject in the DARK condition. These observations were representative for the various types of subjects, as will be shown in more detail when we present data for the group of subjects.

The distribution of the pointing positions of the control subjects were characterized by an ellipsoid with the main axis of the distribution orientated towards the subject's head (see Fig. 2). This finding was particularly obvious in the FRAME condition. It was less obvious in the DARK condition, because control subjects did not always show a significant main orientation of errors for all targets in the DARK condition, in agreement with results of Admiraal *et al.* (2003). Typically, normal control subjects showed a significant orientation for a range of two to four out of five targets (mean 3.1) in the DARK condition, whereas this was the case for four to five out of five targets (mean 4.2) in the FRAME condition. In both conditions, PD patients showed a smaller number of significant main axes than control subjects [mean values of 2.4 (3.5) for the DARK (FRAME) condition]. For the FRAME condition, the orientations of the main axes for mild PD patients were orientated towards the subject's head, similar to that of controls. However, for the DARK condition the main

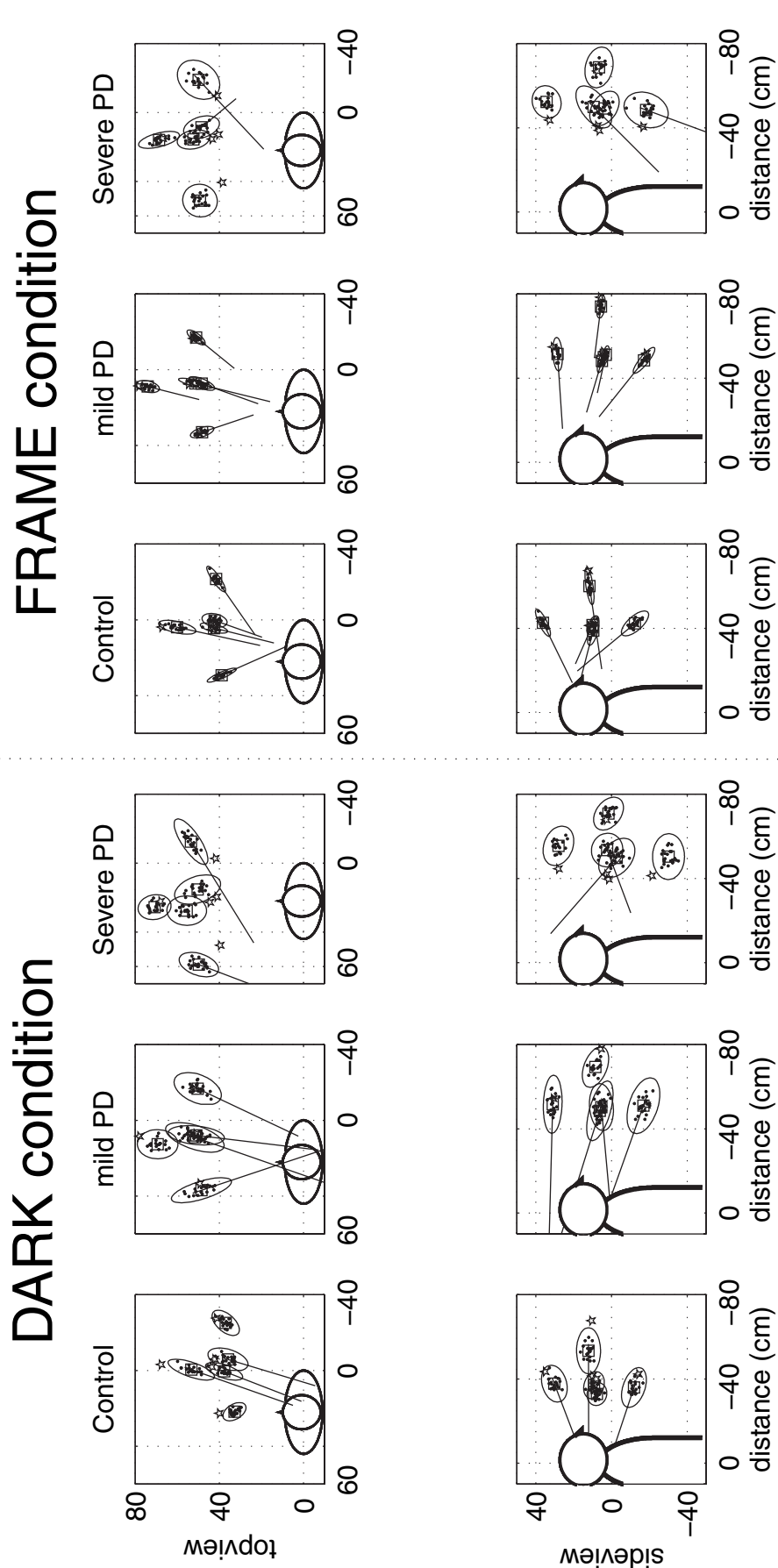

FIG. 2. Top and side view of pointing positions (dots) to the five targets for a control subject, a mild PD patient, and a severe PD patient in the DARK condition (left panels) and in the FRAME condition (right panels). Stars indicate the actual position of the target, squares indicate the average pointing position, and ellipsoids indicate the 95% confidence intervals. Lines emerging from the ellipsoids indicate the direction of the main axis and are only drawn when the distribution has a significant orientation. All targets and pointing positions are presented in an orthogonal coordinate system with the origin at the right shoulder of the subject.

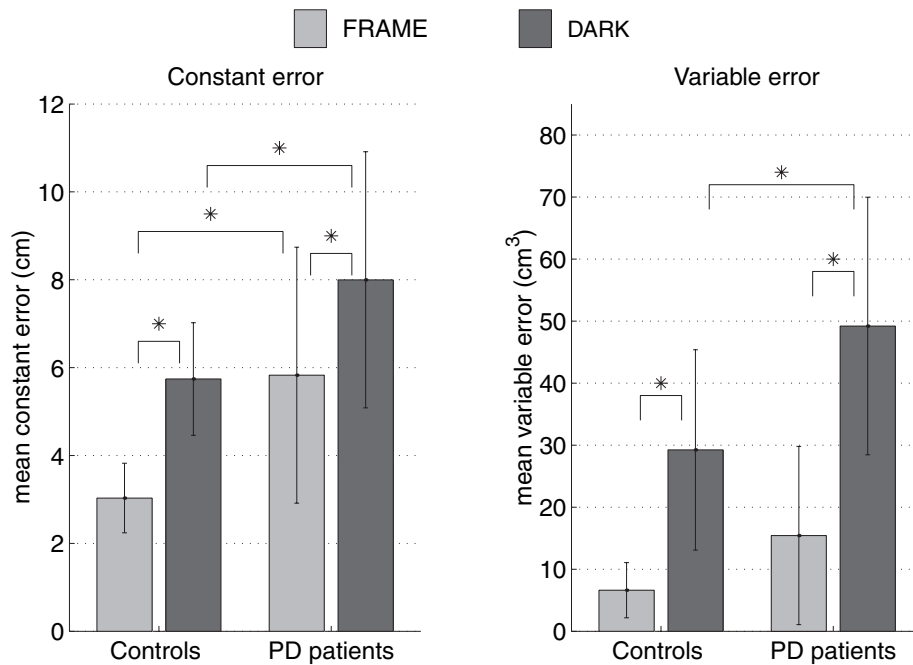

FIG. 3. Mean constant error (left panel) and variable error (right panel) for controls and PD patients. The variable error for pointing to a target was computed as the volume of the ellipsoid with the eigenvectors as the three orthogonal axes, each with the length of the corresponding eigenvalue of the covariance matrix for that target (see Materials and methods). \* $P < 0.05$ . Error bars represent the standard deviation.

orientations of the error ellipsoids, if significant, did not always clearly point towards the subject's head for PD patients. For severe PD patients, this was also true for the FRAME condition.

Figure 3 illustrates the constant and variable errors for the groups of controls and patients in the DARK and FRAME conditions. Pointing errors were consistently smaller for control subjects than for PD patients. This was apparent for both the constant errors (ANOVA, main effect of group,  $F_{1,19} = 6.6$ ,  $P < 0.05$ ) and the variable errors (ANOVA, main effect of group,  $F_{1,19} = 5.9$ ,  $P < 0.05$ ). Not surprisingly, the constant and variable errors were smaller in the FRAME condition than in the DARK condition (ANOVA, main effect of condition, constant error  $F_{1,19} = 79.3$ ,  $P < 0.001$ ; variable error  $F_{1,19} = 64.0$ ,  $P < 0.001$ ). This effect was found both for the controls and the patients. The differences of errors between the FRAME and the DARK condition for the controls and patients were not significantly different, neither for the constant error (ANOVA, interaction effect of group by condition,  $F_{1,19} = 0.98$ ,  $P > 0.3$ ) nor for the variable error (ANOVA, interaction effect of group by condition,  $F_{1,19} = 2.5$ ,  $P > 0.1$ ). Because patients made larger errors than controls, we also calculated the relative reduction of errors in the FRAME condition relative to that in the DARK condition. The relative reduction of errors was defined as the difference of the (constant or variable) errors in the DARK and FRAME condition, divided by the (constant or variable) error in the DARK condition. This analysis showed that the relative reduction of the constant error was significantly smaller for patients ( $29.3 \pm 13.1\%$ ) than for controls ( $45.0 \pm 17.7\%$ ) (unpaired  $t$ -test,  $P < 0.05$ ). For the variable errors, the relative reduction did not differ significantly between patients ( $71.4 \pm 21.7\%$ ) and controls ( $71.3 \pm 30.5\%$ ) (unpaired  $t$ -test,  $P > 0.95$ ).

Analysis of the spatial components did not reveal a significant difference between the mean of the constant error for the group of controls and the group of PD patients. However, the scatter of the constant errors was larger within the group of PD patients than within the group of controls in the FRAME condition in radial distance

( $P < 0.01$ ), azimuth ( $P < 0.05$ ), and elevation ( $P < 0.05$ ). The scatter was not significantly different for PD patients and controls in the DARK condition ( $P > 0.1$ ;  $P > 0.5$ ;  $P > 0.35$  for radial distance, azimuth and elevation, respectively). Both controls and PD patients showed the largest scatter in radial distance both in the DARK condition (approximately 1.8 times larger than for azimuth and elevation) and for the FRAME condition (approximately 2.8 times larger than azimuth and elevation).

#### Correlation analysis

The upper panels of Fig. 4 show the constant error and the variable error (averaged over all targets) as a function of the severity of PD (UPDRS score). The constant error (upper left panel in Fig. 4) did not show a significant effect of the severity of PD in the DARK or in the FRAME condition. The average constant error is significantly smaller in the FRAME condition than in the DARK condition ( $P < 0.001$ , paired  $t$ -test), but the slope as a function of the UPDRS score was not significantly different ( $P = 0.96$ ) in the two conditions. Therefore, the difference of the constant error in the DARK and FRAME condition, which reflects the effect of visual information on the constant error, did not change with the UPDRS score ( $\rho = -0.06$ ; lower left panel in Fig. 4).

For the variable error, there is a clear effect of the severity of PD. The variable error increases significantly with the UPDRS score in the FRAME condition ( $\rho = 0.49$ ,  $P < 0.05$ ; upper right panel in Fig. 4). The decrease of the variable error with the UPDRS score in the DARK condition was not significant. The benefit of visual information for pointing to the remembered visual target becomes evident after subtraction of the error in the FRAME condition from that in the DARK condition. A large difference between the variable pointing errors in the DARK and FRAME condition points to a large benefit of visual information about finger position and the reference frame. The reduction of the variable error in the FRAME condition relative to that

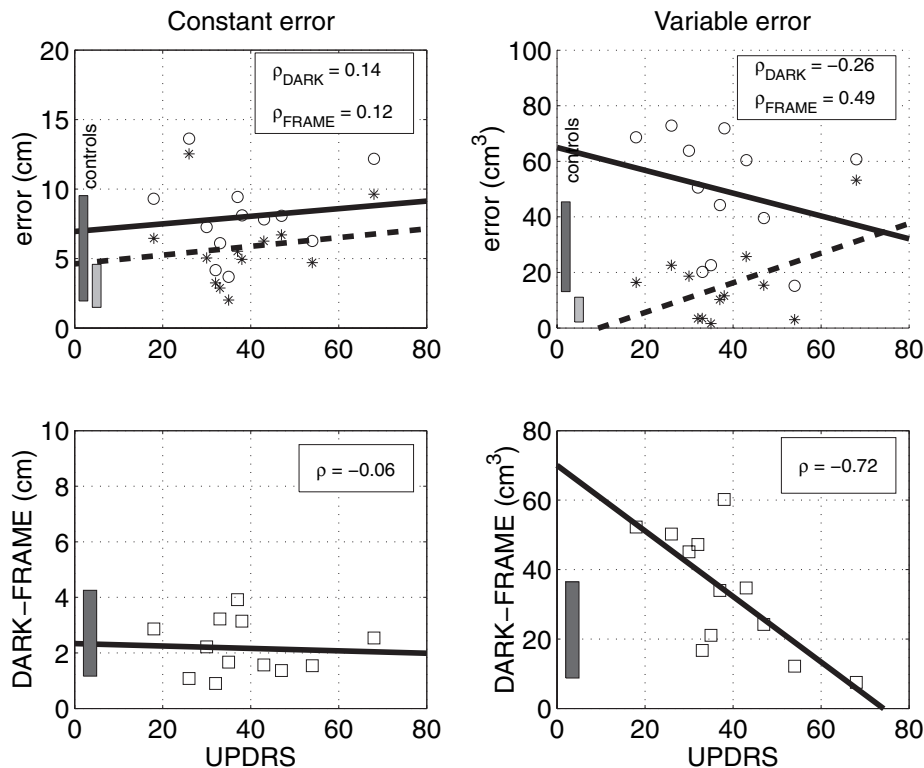

FIG. 4. Relationship between the constant error (left upper panel) and variable error (right upper panel) as a function of the UPDRS score (severity of the disease). Errors are shown for the FRAME condition (asterisks, dashed line) and the DARK condition (circles, solid line). Lower panels show the difference of constant error (lower left panel) and variable error (lower right panel) in the DARK and FRAME condition for each patient as a function of the UPDRS score of that patient. Vertical bars on the left-hand side of the upper panels represent the range of errors (mean error plus or minus the standard deviation) for control subjects in the DARK condition (black bars) and in the FRAME condition (grey bars). Vertical bars in the lower panels indicate the range of the mean plus or minus the standard deviation of the difference of errors in the DARK and FRAME condition for the control subjects ( $\rho$  is the correlation coefficient).

in the DARK condition showed a large and highly significant negative correlation ( $\rho = -0.72$ ,  $P < 0.005$ ) with the severity of PD (lower right panel in Fig. 4).

To obtain more insight into the orientation of the pointing errors relative to the subject, we calculated the spatial components of the variable error in spherical coordinates relative to the subject. The upper panels in Fig. 5 show the components of the variable error in radial distance, azimuth and elevation as a function of the severity of PD. The variable error in radial distance, azimuth, and elevation did not show a significant correlation with the severity of PD in the DARK condition (see Fig. 5). In the FRAME condition, the variable error did not show a significant correlation with the severity of PD for radial distance and azimuth direction. However, the variable error did show a significant positive correlation with the severity of PD for elevation ( $\rho = 0.52$ ,  $P < 0.05$ ).

The lower panels of Fig. 5 show the difference between the variable errors in the DARK and FRAME condition for each of the spatial components. The differences for azimuth and elevation showed a significant negative correlation with the severity of PD ( $\rho = -0.69$ ,  $P < 0.01$  and  $\rho = -0.76$ ,  $P < 0.005$  for azimuth and elevation, respectively). The difference of the variable error in the FRAME and DARK condition did not show a significant correlation with the severity of PD for the radial direction.

## Discussion

In this study we investigated the effect of the severity of PD on the accuracy of pointing movements to remembered visual targets. On

average, PD patients pointed less accurately than controls in the DARK and FRAME condition, which was evident from the larger constant errors in both conditions and from the larger variable error in the DARK condition compared to controls. The severity of PD hardly affected the constant error, but appeared to have a large effect on the variable error; the beneficial effect of visual feedback decreased markedly with increasing severity of PD.

Adamovich *et al.* (2001) studied pointing to remembered targets in PD patients in a similar DARK condition and in a condition with a continuously lit LED on the finger but without visual information about the visual environment (so called 'FINGER condition'). The difference between the FINGER condition in the study of Adamovich *et al.* (2001) and our FRAME condition was that extra visual information about the environment (the illuminated cubic frame) was given in our study, which might have provided an external reference for pointing to the remembered targets. In agreement with our results, Adamovich *et al.* (2001) reported that PD patients had larger variable and constant errors than controls in pointing to remembered targets in the DARK condition. In their FINGER condition they found larger variable errors for PD patients than for controls, but no significant difference between controls and patients was found for the constant error. In our FRAME condition, PD patients showed a significantly larger constant error than controls, but the variable errors were not significantly different. Therefore, we conclude that PD patients point less accurately than controls, especially in the absence of visual information, which is in agreement with results of previous studies on pointing movements in PD patients (Flash *et al.*, 1992; Klockgether & Dichgans, 1994; Poizner *et al.*, 1998; Adamovich *et al.*, 2001; Ketcham *et al.*, 2003).



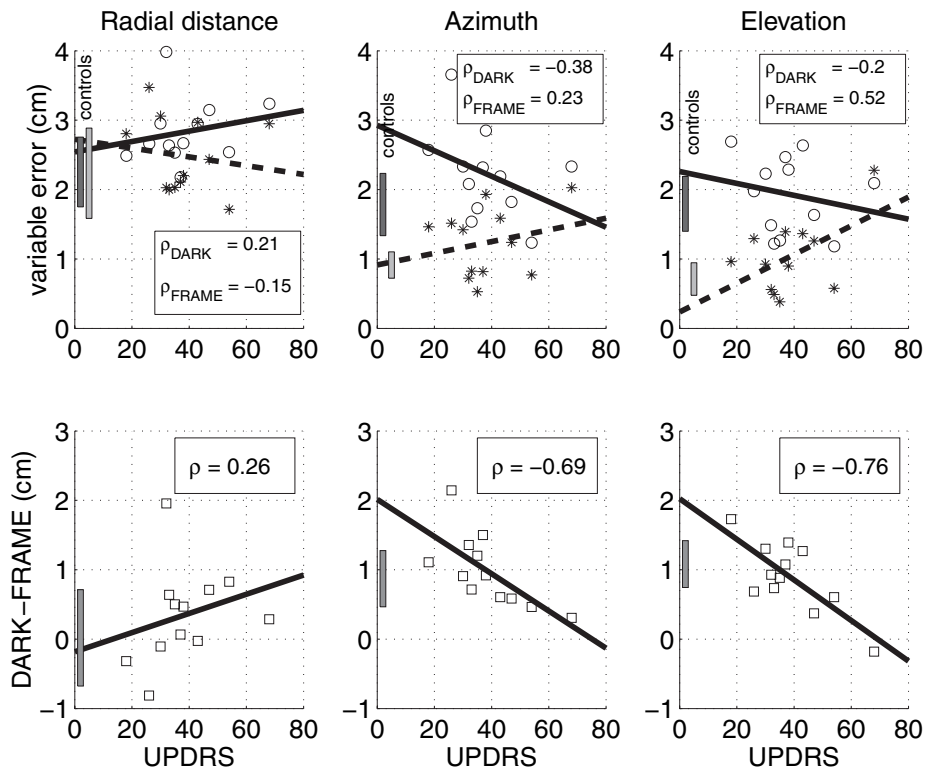

FIG. 5. Upper panels show the spatial components of the variable error in radial distance (upper left panel), azimuth (upper middle panel) and elevation (upper right panel) as a function of the UPDRS score (severity of the disease). Errors are shown for the FRAME condition (asterisks, dashed line) and the DARK condition (circles, solid line). Lower panels show the difference between the spatial components of the variable error in the DARK and FRAME condition. Vertical bars on the left hand side of the panels in the upper row represent the range of the mean error plus or minus the standard deviation for age-matched control subjects in the DARK condition (black bars) and in the FRAME condition (grey bars). Vertical bars in the lower panels represent the range of the mean plus or minus the standard deviation of the difference of the spatial components of the variable error in the DARK and FRAME condition for the control subjects ( $\rho$  is the correlation coefficient).

Subtracting the error in the FRAME condition from the error in the DARK condition reveals the effect of visual information in pointing movements. Control subjects showed a decrease in both the constant error and variable error in the FRAME condition, which was in agreement with previous observations on pointing to remembered visual targets (Soechting & Flanders, 1989a, 1989b; McIntyre *et al.*, 1997, 1998; Admiraal *et al.*, 2003). PD patients showed a similar reduction in variable error and constant error between the FRAME and DARK condition. The main new finding of this study is a significant decrease in the difference of the variable error in the DARK and FRAME conditions as a function of the severity of PD (see lower right panel of Fig. 4). This means that with increasing severity of PD, patients are less able to use visual information to reduce the variability in their movements. This conclusion is supported by the specific effect of visual information on the spatial components of the variable error. The decrease of the variable error between the DARK and FRAME conditions was significantly correlated to the severity of PD for azimuth and elevation, but not for radial direction. This is exactly what one would expect if an effect of vision was involved as Van Beers *et al.* (2002) showed that vision mainly contributes to the accuracy in azimuth and elevation direction, and less so in radial direction.

The orientation of the variable errors for the control subjects was in agreement with the results of earlier studies (Soechting & Flanders, 1989a,b; Soechting *et al.*, 1990; Gordon *et al.*, 1994; Messier & Kalaska, 1997, 1999; Carrozzo *et al.*, 1999; McIntyre *et al.*, 1997, 1998; Desmurget *et al.*, 1998). In the FRAME condition, control subjects showed variable error orientations in a viewer-centred frame of reference with the origin somewhere between the eyes and the

shoulder. In the DARK condition, the distribution of errors was larger in azimuth and elevation for the control subjects, which made it sometimes hard to find a common intersection point of all main axes. In the FRAME condition, mild PD patients showed a main axis that was orientated to an origin somewhere between the subject's eyes and shoulder. This suggests that these mild PD patients operate in a viewer-centred frame of reference, when visual information about the environment is available, just like normal subjects (Soechting *et al.*, 1990; McIntyre *et al.*, 1998; Admiraal *et al.*, 2003). Severe PD patients showed a small number of orientations with a significant main axis and these main axes were in general not orientated towards a common origin. This finding could suggest that severe PD patients operate in a different frame of reference. For example, it might be that patients try to operate in a proprioceptive frame of reference, but do poorly because of their deficit in proprioceptive information processing. Another possibility might be that PD patients, because of a deficit in proprioception and in the absence of visual information in the DARK condition, operate in a feedforward open loop mode. Such feedforward control might be based on motor efference copy outflow via an internal model. It is generally accepted that internal models are rarely perfect (see, e.g. Kawato, 1999) and therefore, such feedforward control is bound to produce errors in pointing. This would be compatible with the larger errors for PD patients in the DARK condition.

In principle, errors in pointing movements to remembered visual targets can be attributed to various factors, such as the misperception of the target position, errors in spatial memory, errors in the transformation from visual information to an appropriate motor



command, or to a deficit in proprioceptive information processing of the arm. The obvious question then is, 'what is the underlying mechanism that is responsible for the larger error in PD patients'? It has been hypothesized that spatial memory might be affected in PD patients (Antal *et al.*, 1998; Postle *et al.*, 1997). However, mild to moderately affected PD patients make the same errors as controls when pointing to a remembered visual target with a Light-Emitting-Diode (LED) on their pointing fingertip in complete darkness (Adamovich *et al.*, 2001) or when pointing to a remembered visual target with the eyes closed (Ketcham *et al.*, 2003). In addition, we found that PD patients did not show significantly different variable errors in the FRAME condition relative to control subjects (see right panel of Fig. 3). The result that PD patients show normal accuracy in pointing to remembered visual targets with visual information suggests that spatial memory is not affected in PD. Moreover, analysis of the spatial components of the constant error did not reveal differences between controls and PD patients in DARK and FRAME condition. These results argue against the hypothesis that misperception of target position or spatial memory might be responsible for the larger errors in pointing to remembered visual targets for PD patients compared to control subjects. In addition, Ketcham *et al.* (2003) found an increase in the variability of end-point errors to remembered target locations in early PD patients. Neither the delay, nor the number of items nor the sequence familiarity of the targets affected the end-point errors in PD patients. This observation of Ketcham *et al.* (2003) suggested that PD patients have an impairment in memory-motor transformation rather than an impairment in spatial memory. Other evidence against a possible role of spatial memory on pointing errors comes from Hodgson *et al.* (1999) who reported that PD patients and control subjects did not differ in the accuracy of eye movements of a remembered saccade to a single target (see also Crawford *et al.*, 1989; Lueck *et al.*, 1992). Therefore, we conclude that there is no evidence for misperception of target location or for an impairment in spatial memory to explain the larger pointing errors to remembered visual targets found in PD patients.

During the execution of a pointing movement, sensorimotor information can be used to correct for errors in end-point positions. In the absence of visual cues, subjects have to rely mainly on proprioceptive information to guide their index finger to the remembered visual target position (Soechting & Flanders, 1989a, 1989b; van Beers *et al.*, 2002). Therefore, the observation of larger variable errors in the DARK condition for PD patients than for controls suggests that patients are less able to use proprioceptive information, in agreement with previous studies (Klockgether *et al.*, 1995; Demirci *et al.*, 1997; Jobst *et al.*, 1997; Zia *et al.*, 2000; Lewis & Byblow, 2002; Maschke *et al.*, 2003). Neither the variable error nor the constant error showed a significant relationship with the severity of PD in the DARK condition. Maschke *et al.* (2003) reported that the percentage of errors in detecting passive displacement of the arm increases with the severity of the disease. As this study dealt with passive arm displacements, whereas our study dealt with errors in active arm positioning, these results are not in conflict. The result in our study suggests that the deficit in the use of proprioceptive information occurs at an early stage of PD, and is hardly affected by further disease progression. In the early stages of the disease, the deficit in proprioceptive information processing is compensated by using visual feedback, because the variable error in the FRAME condition was the same for mildly affected PD patients and controls. However, with progression of the disease, the availability of visual information no longer helps to improve the variable error, indicating a deficit in visual information processing to guide pointing movements.

Taken together, our main conclusion is that pointing movements in PD are impaired due to a deficit in processing of proprioceptive

information, which appears early in the course of the disease, and by a visual feedback problem, which emerges in later stages of the disease.

## Acknowledgements

We wish to thank the patients and volunteers who participated in this study. We thank T. van Dreumel and H. Kleijnen for assistance in building the experimental setup, and we are grateful to G. van Lingen for designing the software to drive the experiment. N.L.W. Keijsers and B.R. Bloem were supported by a research grant of the Prinses Beatrix fonds.

## Abbreviations

PD, Parkinson's disease; ireds, infrared-light-emitting-diodes; LEDs, light-emitting-diodes; UPDRS, Unified Parkinson's Disease Rating Scale.

## References

- Adamovich, S.V., Berkinblit, M.B., Hening, W., Sage, J. & Poizner, H. (2001) The interaction of visual and proprioceptive inputs in pointing to actual and remembered targets in Parkinson's disease. *Neuroscience*, **104**, 1027–1041.
- Admiraal, M.A., Keijsers, N.L.W. & Gielen, C.C.A.M. (2003) Interaction between gaze and pointing toward remembered visual targets. *J. Neurophysiol.*, **90**, 2136–2148.
- Antal, A., Bandini, F., Keri, S. & Bodis-Wollner, I. (1998) Visuo-cognitive dysfunctions in Parkinson's disease. *Clin. Neurosci.*, **5**, 147–152.
- Azulay, J.P., Mesure, S., Amblard, B., Blin, O. & Sangla, I. & Pouget, J. (1999) Visual control of locomotion in Parkinson's disease. *Brain*, **122**, 111–120.
- Barlow, R.J. (1989) *Statistics*. Wiley, Chichester, UK.
- van Beers, R.J., Sittig, A.C. & Denier-van-der-Gon, J.J. (1999) Localization of a seen finger is based exclusively on proprioception and on vision of the finger. *Exp. Brain Res.*, **125**, 43–49.
- van Beers, R.J., Wolpert, D.M. & Haggard, P. (2002) When feeling is more important than seeing in sensorimotor adaptation. *Curr. Biol.*, **12**, 834–837.
- Boecker, H., Ceballos-Baumann, A., Bartenstein, P., Weindl, A., Siebner, H.R., Fassbender, T., Munz, F., Schwaiger, M. & Conrad, B. (1999) Sensory processing in Parkinson's and Huntington's disease: investigations with 3D H (2) (15) O-Pet. *Brain*, **122**, 1651–1665.
- Carrozzo, M., McIntyre, J., Zago, M. & Lacquaniti, F. (1999) Viewer-centered and body-centered frames of reference in direct visuomotor transformations. *Exp. Brain Res.*, **129**, 201–210.
- Cools, A.R., Berger, H.J.C., Buytenhuijs, E.L., Horstink, M.W.I.M. & van Spaendonck, K.P.M. (1993) Manifestation of Switching Disorders in Animals and Man with Dopamine Deficit in A<sub>10</sub> and/or A<sub>9</sub> Circuitries. In Wolters, E.C. & Scheltens, P., (Eds), *Mental dysfunction in Parkinson's disease*. ICG printing, Dordrecht, pp. 49–67.
- Cools, A.R., Jaspers, R., Kolasiewicz, W., Sontag, K.H. & Wolfarth, S. (1983) Substantia nigra as a station that not only transmits, but also transforms, incoming signals for its behavioural expression: striatal dopamine and GABA-mediated responses of pars reticulata neurons. *Behav. Brain Res.*, **7**, 39–49.
- Crawford, T.J., Henderson, L. & Kennard, C. (1989) Abnormalities of non-visual guided eye movements in Parkinson's disease. *Brain*, **112**, 1573–1586.
- Defer, G.L., Widner, H., Marie, R.M., Remy, P. & Levivier, M. (1999) Core assessment program for surgical interventional therapies in Parkinson's disease (CAPSIT-PD). *Mov. Disord.*, **14**, 572–584.
- Delwaide, P.J. & Gonce, M. (1993) Pathophysiology of Parkinson's signs. In Jankovic, J. & Tolosa, E. (Eds), *Parkinson's Disease and Movement Disorders*. Williams & Williams, Baltimore, pp. 77–92.
- Demirci, M., Grill, S., McShane, L. & Hallett, M. (1997) A mismatch between kinesthetic and visual perception in Parkinson's disease. *Ann. Neurol.*, **41**, 781–788.
- Desmurget, M., Pélisson, D., Rossetti, Y. & Prablanc, C. (1998) From eye to hand: planning goal-directed movements. *Neurosci. Biobehav. Rev.*, **22**, 761–788.
- Filion, M., Tremblay, L. & Bedard, P.J. (1988) Abnormal influences of passive limb movement on the activity of globus pallidus neurons in parkinsonian monkeys. *Brain Res.*, **444**, 165–176.
- Flash, T., Inzelberg, R., Schechtman, E. & Korczyn, A.D. (1992) Kinematic analysis of upper limb trajectories in Parkinson's disease. *Exp. Neurol.*, **118**, 215–226.

- Gelissen, M. & Cools, A. (1986) The interrelationship between superior colliculus and substantia nigra pars reticulata in programming movements of cats. *Behav. Brain Res.*, **21**, 85–93.
- Gelissen, M. & Cools, A. (1987a) The interrelationship between superior colliculus and substantia nigra pars reticulata in programming movements of cats: a follow-up. *Behav. Brain Res.*, **25**, 1–11.
- Gelissen, M. & Cools, A. (1987b) Movements of cats on a rotating cylinder: role of the substantia nigra pars reticulata and the deeper layers of the superior colliculus. *Behav. Brain Res.*, **25**, 83–96.
- Gelissen, M. & Cools, A. (1988) Effect of increasing doses of intracaudate haloperidol upon motor expressions that require an intact substantia nigra pars reticulata and/or superior colliculus in cats. *Behav. Brain Res.*, **27**, 205–214.
- Goetz, C.G., Stebbins, G.T., Shale, H.M., Lang, A.E., Chernik, D.A., Chmura, T.A., Ahlskog, J.E. & Dorflinger, E.E. (1994) Utility of an objective dyskinesia rating scale for Parkinson's disease: inter- and intrarater reliability assessment. *Mov. Disord.*, **9**, 390–394.
- Gordon, J., Ghilardi, M.F. & Ghez, C. (1994) Accuracy of planar reaching movements. I. Independence of direction and extent variability. *Exp. Brain Res.*, **99**, 97–111.
- Henderson, J.M., Watson, S., Halliday, G.M., Heinemann, T. & Gerlach, M. (2003) Relationships between various behavioural abnormalities and nigrostriatal dopamine depletion in the unilateral 6-OHDA-lesioned rat. *Behav. Brain Res.*, **139**, 105–113.
- Hodgson, T.L., Dittrich, W.H., Henderson, L. & Kennard, C. (1999) Eye movements and spatial working memory in Parkinson's disease. *Neuropsychologia*, **37**, 927–938.
- Hughes, A.J., Daniel, S.E., Kilford, L. & Lees, A.J. (1992) Accuracy of clinical diagnosis of idiopathic Parkinson's disease: a clinico-pathological study of 100 cases. *J. Neurol. Neurosurg. Psychiatry*, **55**, 181–184.
- Jaspers, R.M., Berkelbach-van-der-Sprekel, J.W. & Cools, A.R. (1989) Progressive pathology of the caudate nucleus, the substantia nigra pars reticulata and the deeper layers of the colliculus superior: acute behavioural and metabolic effects of intrastriatal kainic acid. *Neuroscience*, **28**, 159–169.
- Jaspers, R., Schwarz, M., Sontag, K.H. & Cools, A.R. (1984) Caudate nucleus and programming behaviour in cats: role of dopamine in switching motor patterns. *Behav. Brain Res.*, **14**, 17–28.
- Jobst, E.E., Melnick, M.E., Byl, N.N., Dowling, G.A. & Aminoff, M.J. (1997) Sensory perception in Parkinson disease. *Arch. Neurol.*, **54**, 450–454.
- Kawato, M. (1999) Internal models for motor control and trajectory planning. *Curr. Opin. Neurobiol.*, **9**, 718–727.
- Ketcham, C.J., Hodgson, T.L., Kennard, C. & Stelmach, G.E. (2003) Memory-motor transformations are impaired in Parkinson's disease. *Exp. Brain Res.*, **149**, 30–39.
- Klockgether, T., Borutta, M., Rapp, H., Spieker, S. & Dichgans, J. (1995) A defect of kinesthesia in Parkinson's disease. *Mov. Disord.*, **10**, 460–465.
- Klockgether, T. & Dichgans, J. (1994) Visual control of arm movement in Parkinson's disease. *Mov. Disord.*, **9**, 48–56.
- Lang, A.E. (1995) Clinical rating scales and videotape analysis. In Koller, W.C. & Paulson, G. (Eds), *Therapy of Parkinson's Disease*. Marcel Dekker, New York, pp. 21–46.
- Lewis, G.N., Byblow, W.D. & Walt, S.E. (2000) Stride length regulation in Parkinson's disease: the use of extrinsic, visual cues. *Brain*, **123**, 2077–2090.
- Lewis, G.N. & Byblow, W.D. (2002) Altered sensorimotor integration in Parkinson's disease. *Brain*, **125**, 2089–2099.
- Lueck, C.J., Crawford, T.J., Henderson, L., vanGisbergen, J.A.M., Duysens, J. & Kennard, C. (1992) Saccadic eye movements in Parkinson's disease. II. Remembered saccades-towards a unified hypothesis? *Q. J. Exp. Psychol.*, **45A**, 211–233.
- Martens, D.J., Whishaw, I.Q., Miklyaeva, E.I. & Pellis, S.M. (1996) Spatio-temporal impairments in limb and body movements during righting in an hemiparkinsonian rat analogue: relevance to axial apraxia in humans. *Brain Res.*, **733**, 253–262.
- Maschke, M., Gomez, C.M., Tuite, P.J. & Konczak, J. (2003) Dysfunction of the basal ganglia, but not the cerebellum, impairs kinaesthesia. *Brain*, **126**, 2312–2322.
- McIntyre, J., Stratta, F. & Lacquaniti, F. (1997) Viewer-centered frame of reference for pointing to memorized targets in three-dimensional space. *J. Neurophysiol.*, **78**, 1601–1618.
- McIntyre, J., Stratta, F. & Lacquaniti, F. (1998) Short-term memory for reaching to visual targets: psychophysical evidence for body-centered reference frames. *J. Neurosci.*, **18**, 8423–8435.
- Messier, J. & Kalaska, J.F. (1997) Differential effect of task conditions on errors of direction and extent of reaching movements. *Exp. Brain Res.*, **115**, 469–478.
- Messier, J. & Kalaska, J.F. (1999) Comparison of variability of initial kinematics and endpoints of reaching movements. *Exp. Brain Res.*, **125**, 139–152.
- Poizner, H., Fookson, O.L., Berkinblit, M.B., Hening, W., Feldman, G. & Adamovich, S. (1998) Pointing to remembered targets in 3-D space in Parkinson's disease. *Motor Control*, **2**, 251–277.
- Postle, B.R., Jonides, J., Smith, E.E., Corkin, S. & Growdon, J.H. (1997) Spatial, but not object, delayed response is impaired in early Parkinson's disease. *Neuropsychology*, **11**, 171–179.
- Rickards, C. & Cody, F.W. (1997) Proprioceptive control of wrist movements in Parkinson's disease. Reduced muscle vibration-induced errors. *Brain*, **120**, 977–990.
- Scheel-Kruger, J. (1985) New aspects on the functional role of acetylcholine in the basal ganglia system. In Singh, M., Warburton, D. & Lal, H. (Eds), *Central Cholinergic Mechanisms and Adaptive Dysfunctions*. Plenum Press, New York, pp. 105–139.
- Schneider, J.S., Diamond, S.G. & Markham, C.H. (1987) Parkinson's disease: sensory and motor problems in arms and hands. *Neurology*, **37**, 951–956.
- Soechting, J.F. & Flanders, M. (1989a) Sensorimotor representations for pointing to targets in three-dimensional space. *J. Neurophysiol.*, **62**, 582–594.
- Soechting, J.F. & Flanders, M. (1989b) Errors in pointing are due to approximations in sensorimotor transformations. *J. Neurophysiol.*, **62**, 595–608.
- Soechting, J.F., Helms Tillery, S.I.H. & Flanders, M. (1990) Transformation from head- to shoulder-centred representation of target direction in arm movements. *J. Cogn. Neurosci.*, **2**, 32–43.
- Zia, S., Cody, F. & O'Boyle, D. (2000) Joint position sense is impaired by Parkinson's disease. *Ann. Neurol.*, **47**, 218–228.